

# ROLLCUT

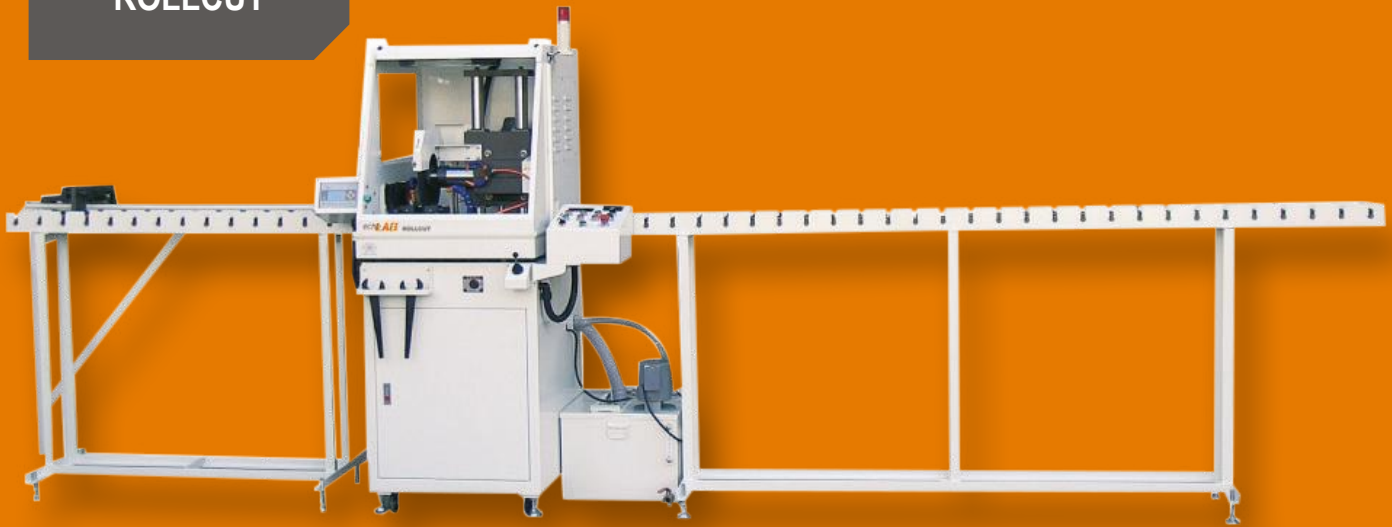

## Features

- > Fully-automatic cutting system complete with a roller table for lateral feeding of very long samples
- > It is equipped with large cutting table that can be used with cutting discs from  $\varnothing$  250mm to  $\varnothing$  400mm
- > Cutting table provided with T-slots to assemble different vices
- > Built-in safety features, internal safety device allows operation only if the cutting chamber is closed
- > Supplied with an external cooling system
- > Large inspection windows allows good visibility of cutting process.

### Standard accessories

Clamp for metallic and non-metallic; cooling tank with pipes; spanners 41mm- 46mm; cutting disc

### Optional accessories

ROLLCUTroll Rolling table for rollcut. Feed rack: 3000mm. Receive rack: 1500mm. The receiving rack is equipped with a digital encoder for cutting length measurement

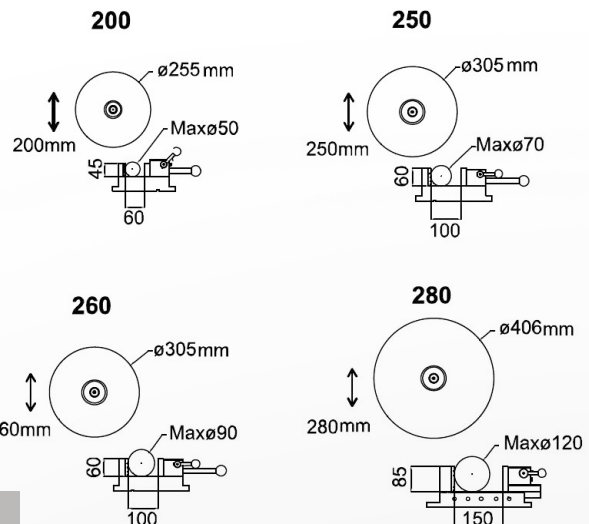

Model	ROLLCUT-200	ROLLCUT-250	ROLLCUT-260	ROLLCUT-280
Cutting capacity	Max. $\varnothing$ 50mm	Max. $\varnothing$ 70mm	Max. $\varnothing$ 90mm	Max. $\varnothing$ 120mm
Cutting disc dimensions	Max. $\varnothing$ 255 x $\varnothing$ 31,75mm	Max. $\varnothing$ 305 x $\varnothing$ 31,75mm	Max. $\varnothing$ 355 x $\varnothing$ 32mm	Max. $\varnothing$ 406 x $\varnothing$ 32mm
Cutting depth	200mm	250mm	260mm	280mm
Working chamber LxW	460x250mm	460x250mm	460x250mm	620x380mm
T-slots table LxW	300x200mm	300x200mm	300x200mm	390x315mm
Speed	2500 (50Hz); 3000 (60Hz) rpm	2500 (50Hz); 3000 (60Hz) rpm	2500 (50Hz); 3000 (60Hz) rpm	2500 (50Hz); 3000 (60Hz) rpm
Noise level	70-80dB	70-80dB	70-80dB	70-80dB
Operating temperature	0÷30°C	0÷30°C	0÷30°C	0÷30°C
Humidity non-condensing	<65%	<65	<65	<65
Motor power	1500W	2200W	3700W	7500W
Power supply	230/400V $\pm$ 10% - 50/60Hz - 1/3Ph	230/400V $\pm$ 10% - 50/60Hz - 1/3Ph	230/400V $\pm$ 10% - 50/60Hz - 1/3Ph	230/400V $\pm$ 10% - 50/60Hz - 1/3Ph
Cooling tank	Capacity	70l	70l	70l
	Dimensions	650x480x700mm	650x480x700mm	650x480x700mm
	Weight	45kg	45kg	45kg
Machine	Dimensions	1150x1500x1800mm	1100x1100x1800mm	1150x1100x1850mm
	Weight	310kg	330kg	355kg